



## Application

- Can be used to transfer clean water or other liquids similar to water in physical and chemical properties
- Suitable for industrial use and urban water supply, pressure boosting for high buildings and fire fighting, garden irrigation, long-distance water transfer, heating ventilation and air controlling, circulation and pressure boosting for cold and hot water, and supporting equipment, etc.

## Pump

- Cast iron pump body and support under special anti-rust treatment
- AISI 304 shaft
- Max. liquid temperature: +40 °C
- Max. suction: 8 m

## Motor

- C&U bearing
- Motor with copper winding
- Built-in thermal protector for single phase motor
- Insulation class: F
- Protection class: IPX4
- Max. ambient temperature: +40 °C

## Identification Codes

**XG m - 1 A**

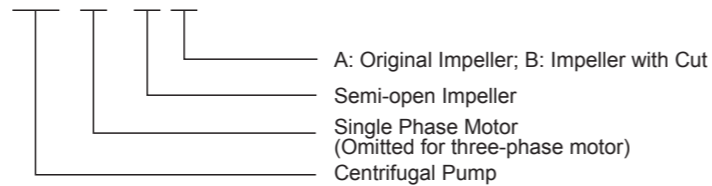

## Technical Data

Model		POWER		Q (m³/h)												
Single Phase	Three Phase	kW	HP	0	2.4	4.2	6	7.8	9.6	11.4	13.2	14.7				
				Q (l/min)	0	40	70	100	130	160	190	220	245			
XGm-1A	XG-1A	0.75	1	H (m)	17.5	16	14.5	13	11	9	6.5	3.5	1			
XGm-1B	XG-1B	0.6	0.8		14	12.5	11	9.5	7.5	5.5	3	-	-			

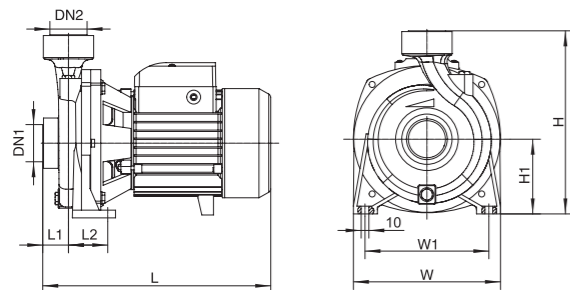

## Dimension

Model	DN1	DN2	L (mm)	W (mm)	H (mm)	L1 (mm)	L2 (mm)	W1 (mm)	H1 (mm)
XGm-1A	1 1/2"	1 1/2"	295	191	235	44	48	160	96.5
XGm-1B									

## Hydraulic Performance Curves

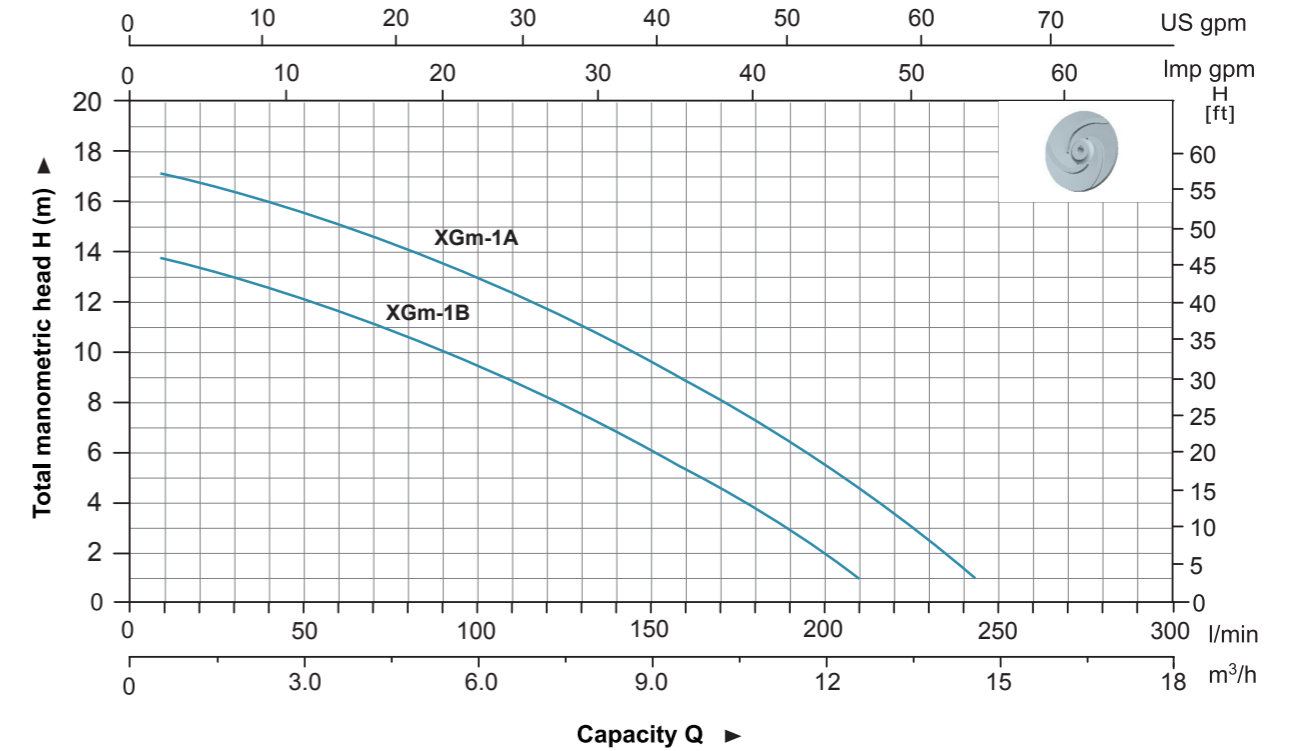

## Materials Table

No.	Part	Material
1	Pump body	HT200
2	Impeller	AISI 304
3	Mechanical seal	Carbon/Ceramic
4	Bracket cover	AISI 304
5	Support	ZL102
6	Bearing	
7	Rotor	
8	Stator	
9	Capacitor	
10	Rear cover	ZL102
11	Fan	PP
12	Fan cover	08F

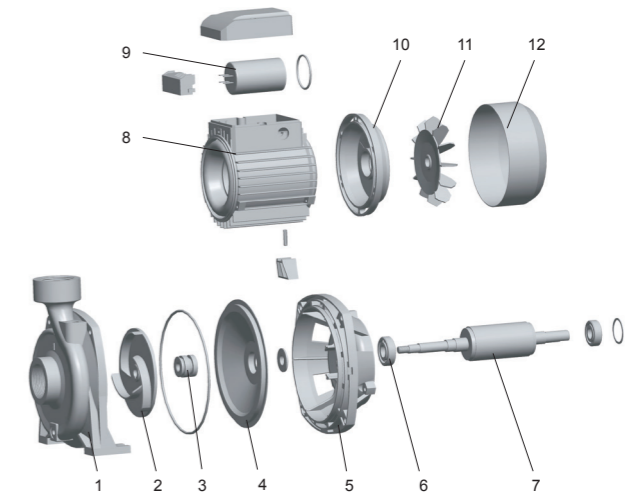

## Package Information

Model	GW (Kgs)	L (mm)	W (mm)	H (mm)	Quantity (PCS/20 TEU)
XGm-1A	13	325	242	265	1512
XGm-1B	11.5	325	242	265	1512

